

SPECIFICATION FOR APPROVAL

CUSTOMER:	TYPE:	T106-2 30uH 电感器
PART NO.:	PM-T1062124700-00	PAGE:
REVISION:	A	ISSUE DATE:
		2015-2-1

1.MECHANICAL DIMENSIONS:(UNIT:mm) REF 2.CONSTRUCTIONS&SCHEMATIC:

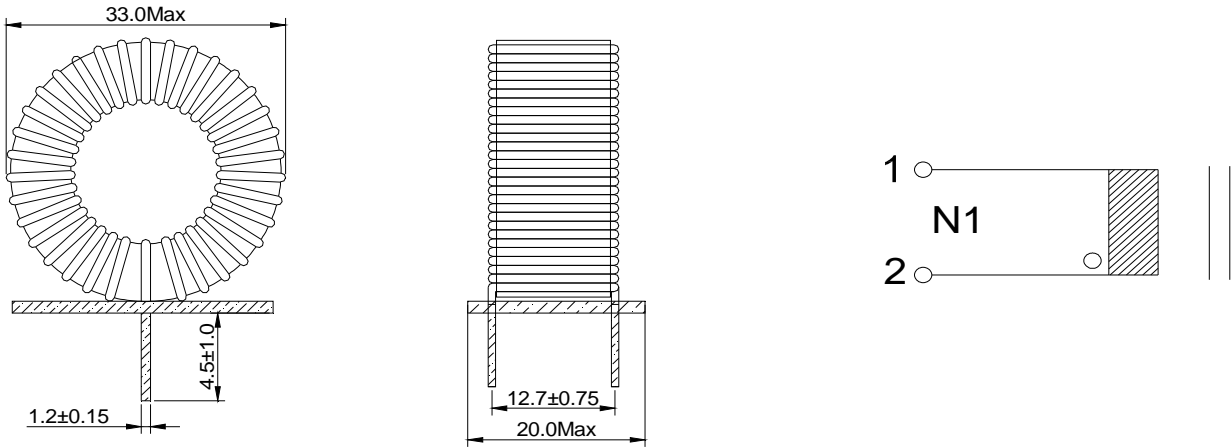

3.WINDING DATA:

WINDING	WIRE SIZE	START	FINISH	TURNS	INDUCTANCE	NOTE
N1	φ 1.2mm *1P	1	2	39TS(Ref)	22.0uH±10%	2UEW

NOTE:ELECTRICAL CHARACTERISTICS

INDUCTANCE:AT 1.0Khz 0.25V RMS
 (3-1).HI -POT TEST:AC 50Hz OR 60Hz
 COIL-CORE:AC 500V/3mA/60S
 (3-2)INSULATION RESISTANCE:
 CORE-COIL DC500V,100MOHM MIN.

4. MATERIAL LIST:

NO	ITEM	MATERIAL	SUPPLIERS	UL NO.
1	WIRE	POLYURETHANE ENAMELLED UEW	PACIFIC ELECTRONIC WIRE &CABLE CO.,LTD <i>OR Other Equivalence</i>	E201757
2	CORE	T106-2	Micrometals, Inc	

DRAWING BY	CHECKED BY	APPROVED BY
I SABEL		